

Starlock Push-on Fasteners for a round shaft

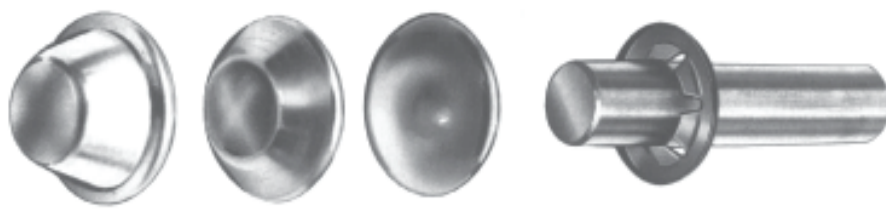
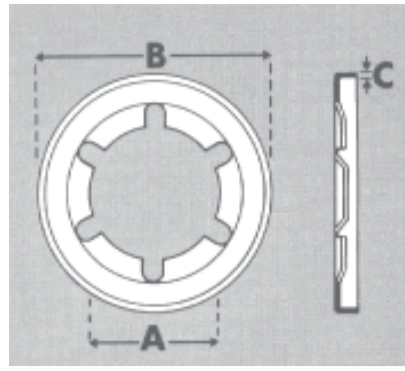

Starlock Push-on Fasteners were designed for use where a quick, permanent and efficient means of assembly is required to retain plain shafts of steel, non-ferrous and plastic materials. They are not normally recommended for use on hard plated or hardened surfaces.

A SHAFT SIZE	PART NO. UNCAPPED	B OUTSIDE DIAMETER	C MATERIAL THICKNESS	PART NO. CAPPED	• SIZE OF CAP	Type of Cap				REMARKS
						DOME	AXLE	DEEP AXLE	NYLON	
1.5mm	6499	.235 - 6.35mm	.008	6669	0	S				
1.5mm	8004	.380 - 9.7mm	.008	7204	1	SK	SK			Standard
1/16	6488	.250 - 6.35mm	.008	6339	0	S				
1/16	6218	.380 - 9.7mm	.008	6232	1	SK	SK			Standard
1.8mm	8054	.380 - 9.7mm	.008	8047	1	SK	SK			
2mm	6933	.250 - 6.35mm	.008	7154	0	S				
2mm	8129	.335 - 8.5mm	.008							
2mm	6489	.380 - 9.7mm	.008	6662	1	SK	SK			Standard
3/32	6330	.250 - 6.35mm	.008	6333	0	S				
3/32	5883	.380 - 9.7mm	.008	6221	1	SK	SK			Standard
2.5mm	7114	.335 - 8.5mm	.008							
.104	6823	.380 - 9.7mm	.008							
3mm	8014	.250 - 6.35mm	.008	6892	1	SK	SK			
3mm	6490	.380 - 9.7mm	.008	8046	0	S				
3mm	8131	.450 - 11.5mm	.008	6663	1	SK	SK	A	N	Standard
3mm	7154	.583 - 14.8mm	.010						N	
3mm	8068	.725 - 18.4mm	.008	8078	4	SK	SK			
3mm	8066	1.108 - 28.15mm	.008	8048	6	SK				
1/8	7025	.250 - 6.35mm	.008	7161	0	S				
1/8	5897	.380 - 9.7mm	.008	6222	1	SK	SK			
3.5mm	8006	.380 - 9.7mm	.008	8032	1	SK	SK			
.144	6833	.380 - 9.7mm	.008	6891	1	SK	SK			
5/32	6707	.375 - 9.53mm	.008							

All dimensions shown are in inches unless otherwise stated and are approximate only.

• FOR DIMENSIONS OF CAPPED STARLOCKS PLEASE REFER TO "GUIDE TO CAP SIZES"

Starlock Push-on Fasteners for a round shaft

"GUIDE TO CAP SIZES"

A SHAFT SIZE	PART NO. UNCAPPED	B OUTSIDE DIAMETER	C MATERIAL THICKNESS	PART NO. CAPPED	• SIZE OF CAP	Type of Cap				REMARKS
						DOME	AXLE	DEEP AXLE	NYLON	
5/32	5928	.450 - 11.5mm	.008	6223	2	SK	SK	A		Standard
4mm	6492	.450 - 11.5mm	.008	6665	2	SK	SK	A		Standard
4mm	7187	.450 - 11.5mm	.010							
4mm	8059	.450 - 11.5mm	.016	8045	2	SK	SK	A		Heavy Duty
4mm	8051	.600 - 15.25mm	.010	8083	3	SK	SK	A	N	
4mm	8064	.725 - 18.4mm	.012	8043	4	SK	SK	A	N	
4mm	8072	.983 - 25.0mm	.010	8079	5	SK	SK	A	N	
4.5mm	7080	.450 - 11.5mm	.008	7206	2	SK	SK	A		
4.7mm	8097	.315 - 8.0mm	.008							
3/16	8018	.380 - 9.7mm	.008	8081	1	SK	SK	A		
3/16	5920	.450 - 11.5mm	.008	6224	2	SK	SK	A		Standard
3/16	6500	.450 - 11.5mm	.012	7245	2	SK	SK	A		
3/16	8058	.450 - 11.5mm	.016	8073	2	SK	SK	A		Heavy Duty
3/16	7127	.600 - 15.25mm	.010	7201	3	SK	SK	A	N	
3/16	6718	.725 - 18.4mm	.012	6680	4	SK	SK	A	N	
5mm	8153	.380 - 9.7mm	.010							
5mm	6491	.450 - 11.5mm	.008	6664	2	SK	SK	A		Standard
5mm	7129	.450 - 11.5mm	.012	8037	2	SK	SK	A		
5mm	8060	.450 - 11.5mm	.016	8074	2	SK	SK	A		Heavy Duty
5mm	7077	.600 - 15.25mm	.010	7250	3	SK	SK	A	N	
7/32	6324	.450 - 11.5mm	.008	6235	2	SK	SK	A		Standard
7/32	6934	.600 - 15.25mm	.010	7155	3	SK	SK	A	N	
7/32	7108	.725 - 18.4mm	.012	8027	4	SK	SK	A	N	
6mm	7126	.450 - 11.5mm	.008	7205	2	SK	SK	A		
6mm	8024	.450 - 11.5mm	.012	8040	2	SK	SK	A		
6mm	8114	.468 - 11.8mm	.008							
6mm	7073	.571 - 14.5mm	.010							
6mm	6493	.600 - 15.25mm	.010	6666	3	SK	SK	A	N	Standard
6mm	7036	.600 - 15.25mm	.014	7160	3	SK	SK	A	N	
6mm	8061	.600 - 15.25mm	.016	8075	3	SK	SK	A	N	Heavy Duty
6mm	8002	.725 - 18.4mm	.012	8031	4	SK	SK	A	N	
1/4	5873	.600 - 15.25mm	.010	6225	3	SK	SK	A	N	Standard
1/4	7068	.600 - 15.25mm	.014	7244	3	SK	SK	A	N	
1/4	8052	.600 - 15.25mm	.016	8041	3	SK	SK	A	N	Heavy Duty
1/4	7029	.725 - 18.4mm	.012	7159	4	SK	SK	A	N	

All dimensions shown are in inches unless otherwise stated and are approximate only.

• FOR DIMENSIONS OF CAPPED STARLOCKS PLEASE REFER TO "GUIDE TO CAP SIZES"

Starlock Push-on Fasteners for a round shaft

A SHAFT SIZE	PART NO. UNCAPPED	B OUTSIDE DIAMETER	C MATERIAL THICKNESS	PART NO. CAPPED	• SIZE OF CAP	Type of Cap				REMARKS
						DOME	AXLE	DEEP AXLE	NYLON	
1/4	8010	.983 - 25.0mm	.010							
1/4	8023	1.108 - 28.15mm	.010	8039	6	SK		A	N	
6.75mm	7030	.725 - 18.4mm	.010	7158	4	SK	SK	A	N	
7mm	6703	.600 - 15.25mm	.016	6670	3	SK	SK	A	N	Standard
7mm	8153	.600 - 15.25mm	.010	8085	3	SK	SK	A	N	Heavy Duty
9/32	6326	.600 - 15.25mm	.010	6236	3	SK	SK	A	N	Standard
9/32	6937	.725 - 18.4mm	.010	7167	4	SK	SK	A	N	
9/32	6938	.983 - 25.0mm	.010	7168	5	SK	SK	A	N	
9/32	7136	1.437 - 36.5mm	.010	8028	7	SK			N	
5/16	5821	.600 - 15.25mm	.010	6226	3	SK	SK	A	N	Standard
5/16	7037	.600 - 15.25mm	.012	7169	3	SK	SK	A	N	
8mm	6704	.600 - 15.25mm	.010	6671	3	SK	SK	A	N	Standard
8mm	8062	.600 - 15.25mm	.016	8076	3	SK	SK	A	N	Heavy Duty
8mm	7192	.725 - 18.4mm	.012	7207	4	SK	SK	A	N	
8mm	7067	.983 - 25.0mm	.012	7243	5	SK	SK	A	N	
8.5mm	7101	.600 - 15.25mm	.010	8033	3	SK	SK	A	N	
11/32	6332	.725 - 18.4mm	.012	6238	4	SK	SK	A	N	Standard
11/32	7109	.983 - 25.0mm	.012	8029	5	SK	SK	A	N	
9mm	6708	.725 - 18.4mm	.012	6674	4	SK		A	N	Standard
.365	6213	.725 - 18.4mm	.012	6233	4	SK	SK	A	N	Standard
3/8	6020	.725 - 18.4mm	.012	6227	4	SK	SK	A	N	Standard
3/8	6482	.725 - 18.4mm	.012	7172	4	SK	SK	A	N	
3/8	6931	1.625 - 41.28mm	.020	7153	9	SK			N	
10mm	6496	.725 - 18.4mm	.012	6668	4	SK	SK	A	N	Standard
10mm	8130	.725 - 18.4mm	.016	8082	4	SK	SK	A	N	
10mm	7074	.983 - 25.0mm	.016	7249	5	SK	SK	A	N	
13/32	6331	.725 - 18.4mm	.012	6239	4	SK	SK	A	N	Standard
13/32	7110	.983 - 25.0mm	.016	7208	5	SK	SK	A	N	
11mm	6706	.725 - 18.4mm	.012	6673	4	SK	SK	A	N	Standard
7/16	6494	.725 - 18.4mm	.012	6661	4	SK	SK	A	N	
7/16	6216	.983 - 25.0mm	.016	6228	5	SK	SK	A	N	Standard
11.5mm	8065	.966 - 24.54mm	.016							
12mm	6713	.983 - 25.0mm	.016	6675	5	SK	SK	A	N	Standard
1/2	6143	.983 - 25.0mm	.016	6229	5	SK	SK	A	N	Standard
13mm	6829	.983 - 25.0mm	.016	6885	5	SK	SK	A	N	Standard

All dimensions shown are in inches unless otherwise stated and are approximate only.

• FOR DIMENSIONS OF CAPPED STARLOCKS PLEASE REFER TO "GUIDE TO CAP SIZES"

A SHAFT SIZE	PART NO. UNCAPPED	B OUTSIDE DIAMETER	C MATERIAL THICKNESS	PART NO. CAPPED	• SIZE OF CAP	Type of Cap				REMARKS
						DOME	AXLE	DEEP AXLE	NYLON	
17/32	6325	.983 - 25.0mm	.016	6237	5	SK	SK	A	N	Standard
14mm	7065	.905 - 23.0mm	.016							
14mm	7078	.983 - 25.0mm	.016	8034	5	SK		A	N	
14mm	6825	1.108 - 28.15mm	.016	6881	6	SK			N	Standard
15mm	6714	1.108 - 28.15mm	.016	6676	6	SK			N	Standard
5/8	6200	.983 - 25.0mm	.008	8077	5	SK		A	N	
5/8	6185	.983 - 25.0mm	.016	6231	5	SK	SK	A	N	Standard
16mm	6826	1.108 - 28.15mm	.016	6882	6	SK			N	Standard
17mm	6715	1.108 - 28.15mm	.016	6677	6	SK			N	Standard
18mm	8001	1.108 - 28.15mm	.016	8035	6	SK			N	
18mm	8125	1.220 - 31.0mm	.012							
18mm	6827	1.437 - 36.5mm	.016	6883	7	SK			N	Standard
18.4mm	8110	1.108 - 28.15mm	.016							
19mm	6828	1.437 - 36.5mm	.016	6884	7	SK			N	Standard
3/4	6323	1.437 - 36.5mm	.008							
3/4	6322	1.437 - 36.5mm	.016	6234	7	SK			N	Standard
19.85mm	8064	1.108 - 28.15mm	.016							
20mm	6716	1.437 - 36.5mm	.016	6678	7	SK			N	Standard
20mm	8057	1.437 - 36.85mm	.020							
20mm	8109	1.625 - 41.28mm	.020							
21mm	6830	1.437 - 36.5mm	.016	6886	7	SK			N	Standard
22mm	6719	1.437 - 36.5mm	.016	6889	7	SK			N	Standard
7/8	6328	1.500 - 38.1mm	.018	6335	8	SK				Standard
23mm	6831	1.500 - 38.1mm	.018	6887	8	SK				Standard
24mm	7035	1.500 - 38.1mm	.018	7241	8	SK				
24mm	6832	1.625 - 41.28mm	.020	6888	9	SK			N	Standard
25mm	7034	1.500 - 38.1mm	.020	7241	8	SK				
25mm	8103	1.500 - 38.1mm	.012			SK				
25mm	6717	1.625 - 41.28mm	.020	6679	9	SK			N	Standard
1	8149	1.625 - 41.28mm	.012	8084	9	SK			N	
1	6329	1.625 - 41.28mm	.020	6334	9	SK			N	Standard
27mm	7194	1.625 - 41.28mm	.020	8036	9	SK			N	
1-1/8	7061	1.625 - 41.28mm	.020	7248	9	SK			N	