

Starlock Push-on Fasteners for a round shaft

“GUIDE TO CAP SIZES”

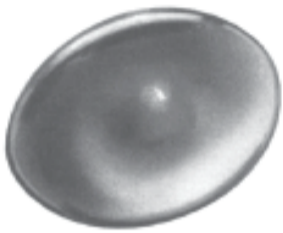
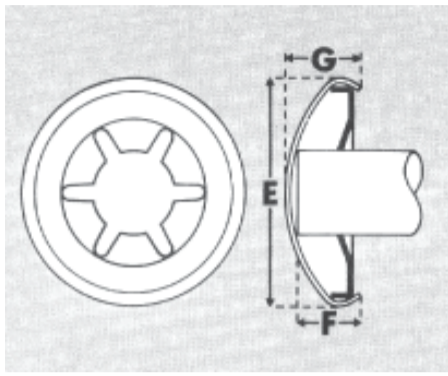

Size of Cap	E Outside Diameter		F Maximum Depth of Penetration of Shaft		G Height	
	IMPERIAL CAP SIZES Inches	METRIC CAP SIZES MM	IMPERIAL CAP SIZES Inches	METRIC CAP SIZES MM	IMPERIAL CAP SIZES Inches	METRIC CAP SIZES MM
0	.285	7.2	.055	1.4	.105	2.70
1	.420	10.67	.100	2.54	.120	3.05
2	.485	12.32	.120	3.05	.148	3.76
3	.640	16.32	.160	4.06	.200	5.08
4	.780	19.81	.177	4.50	.230	5.80
5	1.025	26.0	.236	6.00	.295	7.50
6	1.157	29.4	.276	7.00	.354	9.00
7	1.505	38.2	.343	8.70	.460	11.70
8	1.565	39.8	.375	9.53	.510	12.95
9	1.695	43.0	.375	9.53	.490	12.45

All dimensions are approximate only.

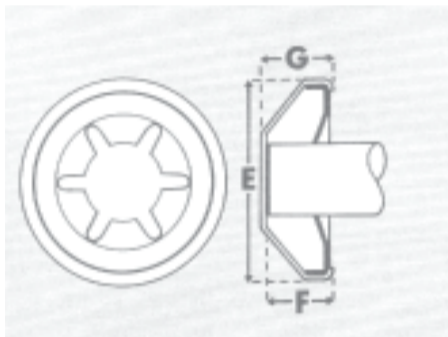

Size of Cap	E Outside Diameter		F Maximum Depth of Penetration of Shaft		G Height	
	IMPERIAL CAP SIZES Inches	METRIC CAP SIZES MM	IMPERIAL CAP SIZES Inches	METRIC CAP SIZES MM	IMPERIAL CAP SIZES Inches	METRIC CAP SIZES MM
1	.420	10.67	.135	3.43	.157	3.96
2	.490	12.45	.160	4.06	.175	4.45
3	.640	16.26	.180	4.55	.200	5.08
4	.785	19.82	.216	5.50	.235	5.97
5	1.028	26.11	.270	6.86	.285	7.24

All dimensions are approximate only.

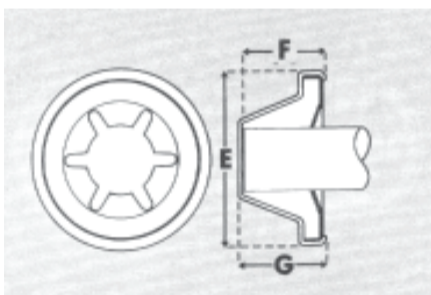

Size of Cap	E Outside Diameter		F Maximum Depth of Penetration of Shaft		G Height	
	IMPERIAL CAP SIZES Inches	METRIC CAP SIZES MM	IMPERIAL CAP SIZES Inches	METRIC CAP SIZES MM	IMPERIAL CAP SIZES Inches	METRIC CAP SIZES MM
0	.285	7.2	.055	1.4	.105	2.70
1	.420	10.67	.100	2.54	.120	3.05
2	.485	12.32	.120	3.05	.148	3.76
3	.640	16.32	.160	4.06	.200	5.08
4	.780	19.81	.177	4.50	.230	5.80
5	1.025	26.0	.236	6.00	.295	7.50
6	1.157	29.4	.276	7.00	.354	9.00
7	1.505	38.2	.343	8.70	.460	11.70
8	1.565	39.8	.375	9.53	.510	12.95
9	1.695	43.0	.375	9.53	.490	12.45

All dimensions are approximate only.

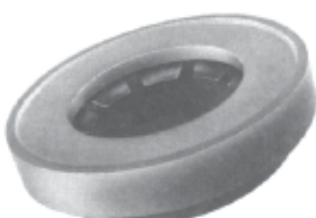
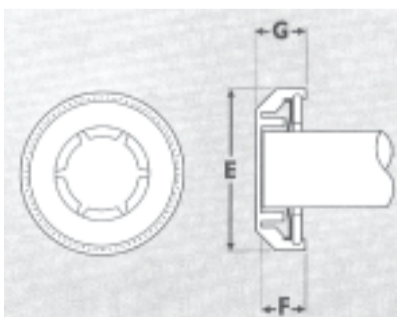

Size of Cap	E Outside Diameter		F Maximum Depth of Penetration of Shaft		G Height	
	IMPERIAL CAP SIZES Inches	METRIC CAP SIZES MM	IMPERIAL CAP SIZES Inches	METRIC CAP SIZES MM	IMPERIAL CAP SIZES Inches	METRIC CAP SIZES MM
1	.420	10.67	.135	3.43	.157	3.96
2	.490	12.45	.160	4.06	.175	4.45
3	.640	16.26	.180	4.55	.200	5.08
4	.785	19.82	.216	5.50	.235	5.97
5	1.028	26.11	.270	6.86	.285	7.24

All dimensions are approximate only.