

Standard Brake and Clutch Rivet Data

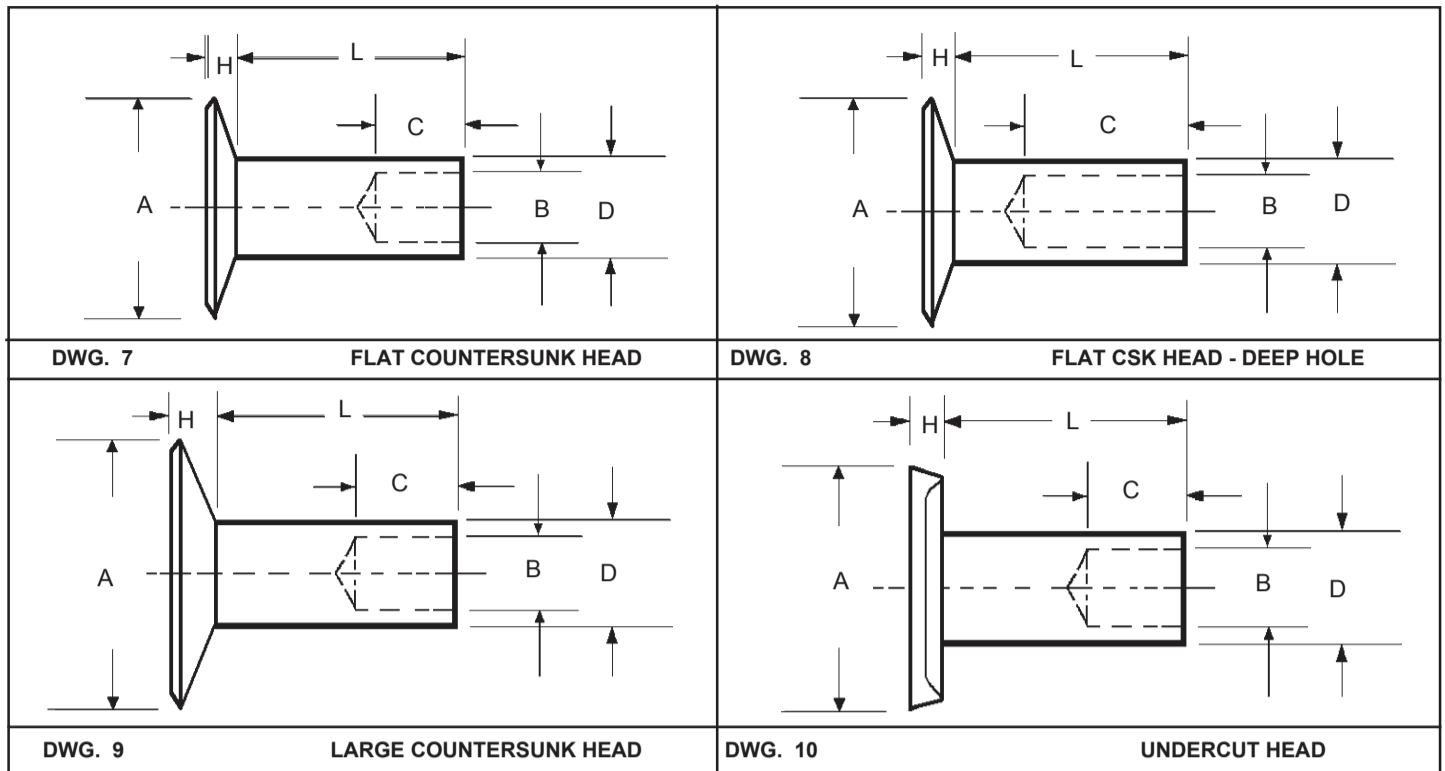

PLEASE SPECIFY DIMENSION "L" WHEN ORDERING

NOM. SHANK DIA."	NOM. HEAD DIA."	DWG.	RECOMM. HOLE DIA. IN ASSEMBLY"	MIN. CLINCH ALLOW."	SHANK DIA." D	HEAD DIA." A	HEAD THICK." H	HOLE DIA." B	HOLE DEPTH" C	PART NUMBERS FOR STEEL RIVETS
1/8	15/64	7	.128	.062	.121 .125	.231 .240	.029 .035	.087	.190	S2
9/64	19/64	8	.152	.125	.141 .146	.285 .305	.035 .045	.102	.218	S3
9/64	19/64	7	.152	.093	.141 .146	.285 .305	.035 .045	.102	.140	S4
9/64	23/64	9	.152	.093	.141 .146	.349 .369	.041 .051	.102	.140	S5
9/64	23/64	9	.152	.125	.141 .146	.349 .369	.041 .051	.102	.218	S16 ●

BRAKE and CLUTCH RIVET HEADS CAN BE CUSTOM IMPRINTED, IF REQUIRED. STEPHENS CAN ALSO SUPPLY SPECIAL TOOLING FOR YOUR RIVETER TO CUSTOM IMPRINT THE RIVET HEAD DURING INSTALLATION. PLEASE INQUIRE.

- ◆ Hole depth may be less for shortest lengths ● This item is not normally stocked. Made to order.
 ■ BRAKE and CLUTCH RIVETS CAN ALSO BE MADE FROM BRASS AND OTHER MATERIALS. PLEASE INQUIRE.

NOM. SHANK DIA."	NOM. HEAD DIA."	DWG.	RECOMM. HOLE DIA. IN ASSEMBLY"	MIN. CLINCH ALLOW."	SHANK DIA." D	HEAD DIA." A	HEAD THICK." H	HOLE DIA." B	HOLE DEPTH" C	PART NUMBERS FOR STEEL RIVETS
9/64	19/64	10	.152	.093	.141 .146	.285 .305	.035 .045	.102	.140	S22
5/32	19/64	10	.165	.093	.151 .156	.285 .305	.035 .045	.110	.140	S15 ●
5/32	19/64	8	.165	.125	.151 .156	.285 .305	.035 .045	.110	.250	S21 ●
5/32	23/64	9	.165	.125	.151 .156	.349 .369	.041 .051	.110	.250	S11 ●
3/16	23/64	7	.196	.110	.182 .188	.349 .369	.041 .051	.136	.187	S7
3/16	15/32	9	.196	.110	.182 .188	.464 .484	.053 .067	.136	.187	S8
3/16	23/64	8	.196	.156	.182 .188	.349 .369	.041 .051	.136	.281	S17 ●
3/16	23/64	10	.196	.110	.182 .188	.349 .369	.035 .045	.136	.187	S24
.197	15/32	9	.209	.110	.195 .200	.453 .468	.055 .069	.142	.187	S20
.197	23/64	10	.209	.110	.195 .200	.349 .369	.035 .045	.142	.187	S25 ❖
.210	23/64	10	.218	.115	.207 .213	.349 .369	.035 .045	.167	.187	S23
.210	23/64	7	.218	.115	.207 .213	.349 .369	.041 .051	.167	.187	S27 ●
1/4	15/32	7	.266	.156	.244 .252	.464 .484	.053 .067	.178	.250	S10

STEPHENS OFFERS A COMPLETE RANGE OF NEW AND USED RIVETERS FOR ALL APPLICATIONS.

- ◆ Hole depth may be less for shortest lengths. ● These items are not normally stocked. ❖ The STEPHENS S25 is also referred to as S23.5.
 ■ BRAKE and CLUTCH RIVETS CAN ALSO BE MADE FROM BRASS AND OTHER MATERIALS. PLEASE INQUIRE.